

# POWLEY VACUUM PRESSURE SEALS



Repacking worn glands with mechanical seals can be a time consuming and expensive exercise, especially if the need arises during a long-term contract where continuous pumping operations are essential. Vacuum Pressure Seals is the practical solution.

770-345-9430

or 770-337-0130

Fax 770-345-9431

[sales@powleypumps.com](mailto:sales@powleypumps.com)

[www.powleypumps.com](http://www.powleypumps.com)

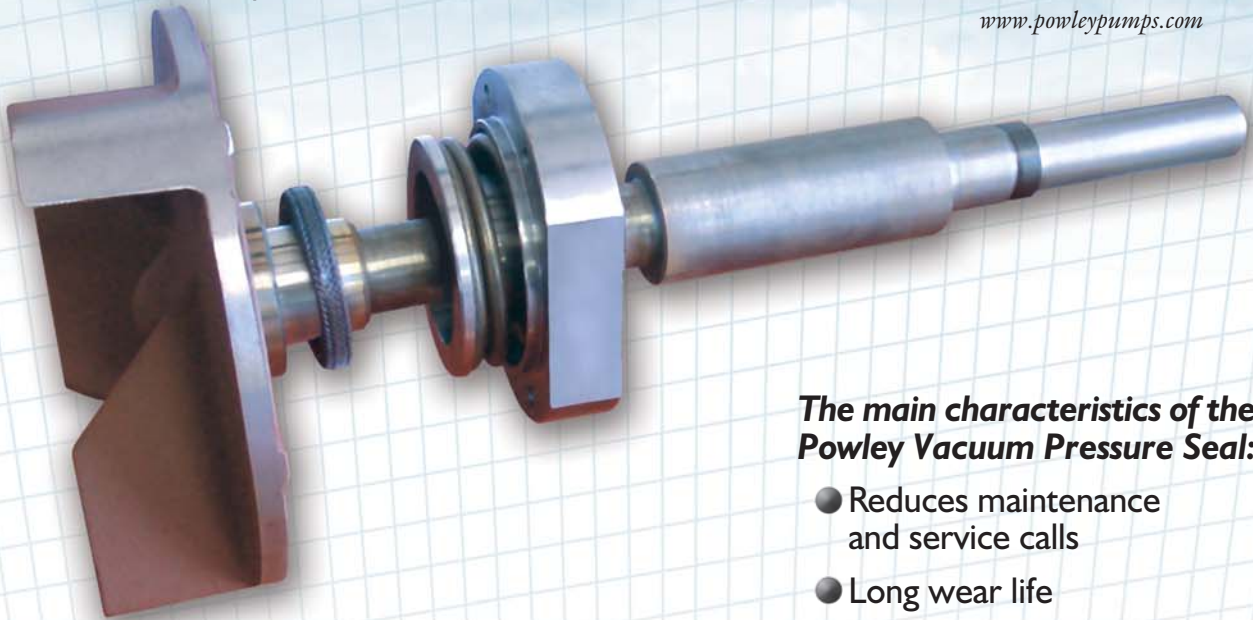

To alleviate this problem, and save you time and money, Powley utilizes their one piece vacuum pressure seal, which offers approximately three times more working life than the conventional gland, and ***In Excess Of Two Thousand Hours Of Maintenance Free Operation.***

## The main characteristics of the Powley Vacuum Pressure Seal:

- Reduces maintenance and service calls
- Long wear life
- Self adjusting
- Simple to repack in the field
- Cannot be abused while in operation
- Cannot be accidentally overtightened
- Leak-proof

## SEAL COMPOSITION "The Heart Of Any Pump"



One Piece Gland Housing

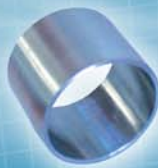

Renewable Sleeve



Packing Holder



Gland Packing

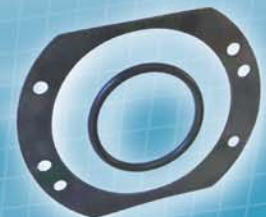

O-Ring Gasket

### Distribution & Workshop

295 Gateway Drive ¶ Suite 201 ¶ Canton, Georgia 30114

770-345-9430 or 770-337-0130 Fax 770-345-9431

### Administration & Accounts Office

551 Wentworth Court ¶ Canton, Georgia 30114

[sales@powleypumps.com](mailto:sales@powleypumps.com) [www.powleypumps.com](http://www.powleypumps.com)

# POWLEY VACUUM PRESSURE SEALS



## GENERAL CONSTRUCTION AND OPERATION

The seal comprises a fixed packing holder containing one round of graphite packing running against a precision machined surface.

It is self-adjusting and leak proof for the whole of its entire working life, and it automatically adjusts to site conditions by

making use of differential pressures between the seal faces. So no site adjustment is ever needed, alleviating the problems of over or under tightening and of general site abuse.

Due to its consistent operation, greater reliability of pump performance is

achieved, and with it, a subsequent reduction in service calls and maintenance costs.

Powley Vacuum Pressure seals can be easily repacked in the field without the need to dismantle the pump, and will give consistent performance throughout their working life.

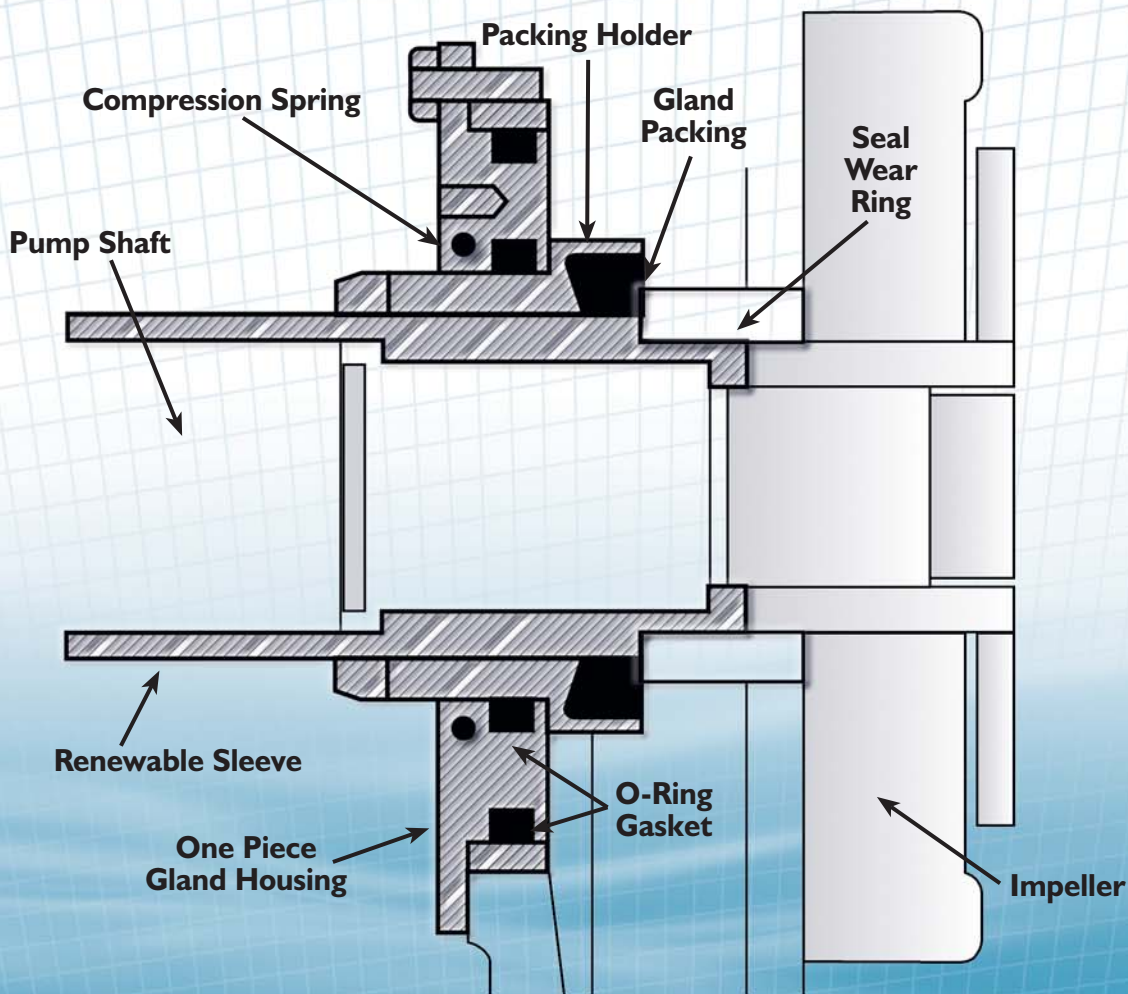

## TYPICAL ARRANGEMENT OF THE VACUUM PRESSURE SEAL

### Distribution & Workshop

295 Gateway Drive ☿ Suite 201 ☿ Canton, Georgia 30114

770-345-9430 or 770-337-0130 Fax 770-345-9431

### Administration & Accounts Office

551 Wentworth Court ☿ Canton, Georgia 30114

sales@powleypumps.com www.powleypumps.com

PROUDLY MANUFACTURED IN THE U.S.A.